

Section 1

General Information

The IntelliBar is a thermal label printer that uses industry-standard printer command languages to produce high-resolution fonts, graphics, and bar codes on thermal transfer or direct thermal paper or synthetic rolls of labels or tag stock.

The IntelliBar printer family consists of four series differentiated by the printer command language, emulation, and connectivity as listed in Table 1-1.

Table 1-1 IntelliBar Printer Product Line

Series Name	Printer Command Language	Emulation	Connectivity
IntelliBar Standard Series	Hewlett Packard Printer Control Language 5 (HP PCL5)	LaserJet III	IEEE 1284 parallel, RS-232/RS422C serial
IntelliBar AS Series	AFP/IPDS, HP PCL5	IBM 4028	IEEE 1284 parallel, RS-232/RS422C serial, 10BaseT Twinax or Coax
IntelliBar ax Series	SCS, HP PCL5	IBM 5020	10BaseT Twinax or Coax, IEEE 1284 parallel, RS-232/RS422C serial
IntelliBar LPR Series	IGP/PGL, IGP/VGL Magnum Code V, HP PCL5	Printronix, Centronics, QMS	10BaseT Twinax or Coax, IEEE 1284 parallel, RS-232/RS422C serial

Each series consists of three models: Model 48, Model 412 and Model 88. All models print using either the thermal transfer or direct thermal printing method described later in this section. As standard features, all printers have 300 x 300 dots per inch (dpi) print resolution, parallel and serial communication ports, and label peel-off capability. The IntelliBar AS, ax, and LPR Series have the additional standard feature of twinax and coax connectivity. Each model also features a control panel and LCD display for simple printer installation and use (see “Control Panel” in this section).

The Model 48 and Model 412 print labels up to a maximum width of 4.37 inches (111 mm). The Model 88 prints labels up to a maximum width of 8.65 inches (220 mm). Label length is model and memory dependent. In the Model 48 and Model 412, memory can be expanded to increase label length, overall printer performance, and data throughput. The IntelliBar automatically senses label length at power-on and provides a backfeeding capability used with tear-off, peel-off, or cut-off printing modes.

Print output can include text and graphics in addition to high-density bar codes, extending the IntelliBar printer's versatility for any label printing need.

Depending on the IntelliBar model and the main board revision, other features include:

- an operating speed of up to 8 inches per second (ips) for the Model 48 and Model 88, and 12 ips for the Model 412.
- HP PCL 5 compatibility and LaserJet III printer command set emulation with 14 bitmap and eight outline fonts (in addition to specific printer command languages for the various IntelliBar printer series as described in Table 1-1). Support includes all PCL 5 commands and functions with several additional command extensions to deal with special printer features that are not available in the HP LaserJet (see the *IntelliBar Programmer's Reference Guide* for more information).
- a minimum of 2 MB of random-access memory (RAM) expandable (in the Model 48 and Model 412) using SIMM option installation (see "Memory Expansion" in this section).

MODELS 48 AND 412

Features common to Models 48 and 412 are shown in Figure 1-1 and Figure 1-2 and described in the following subsections. For printer specifications, see "Specifications" in this section.

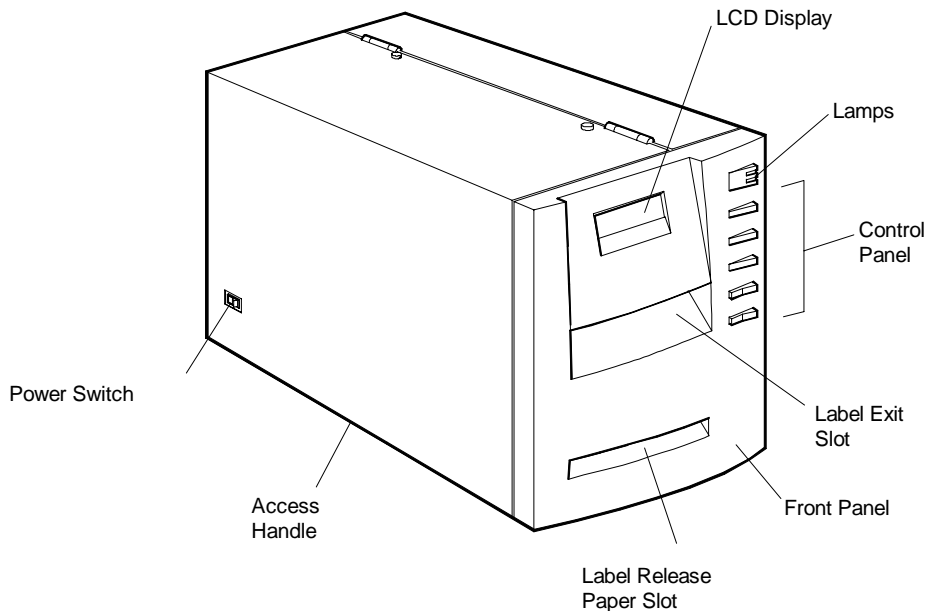

Figure 1-1 Model 48 and Model 412 Features (Front and Left Side View)

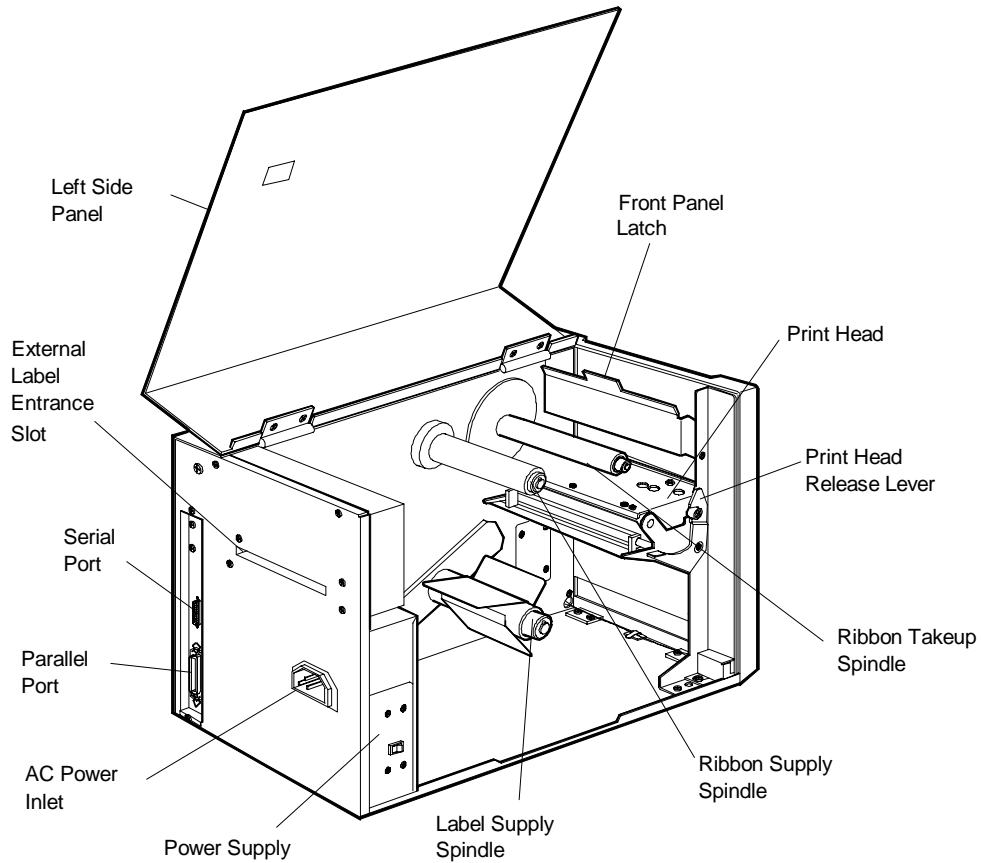

Figure 1-2 Model 48 and Model 412 Features (Rear and Left Side View)

MODEL 88

The features of the Model 88 are shown in Figure 1-3 and Figure 1-4 and described in the following subsections. For printer specifications, see “Specifications” in this section.

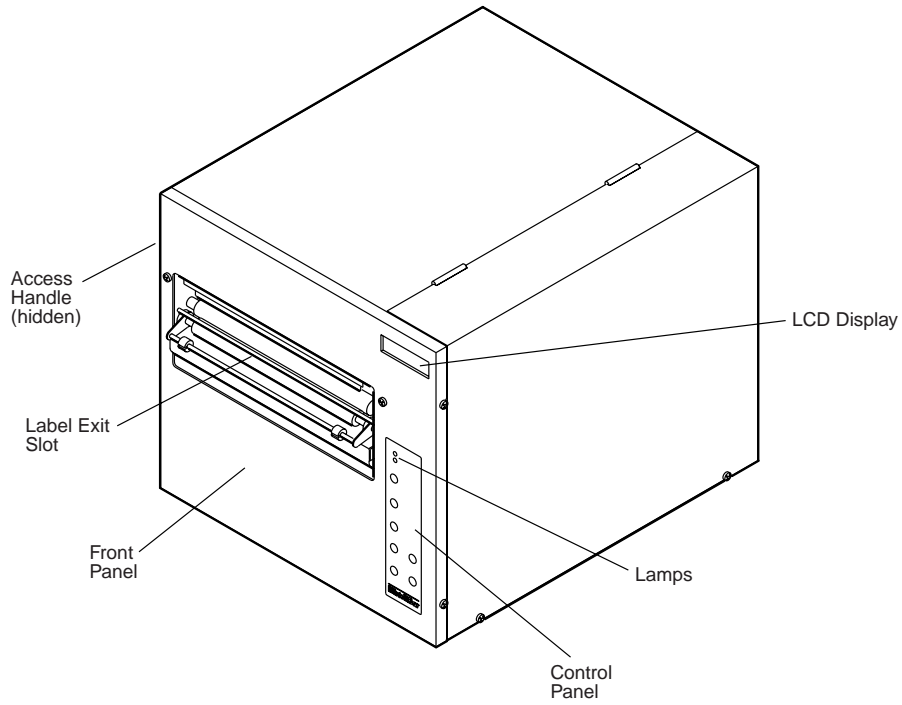

Figure 1-3 Model 88 Features (Front and Right Side View)

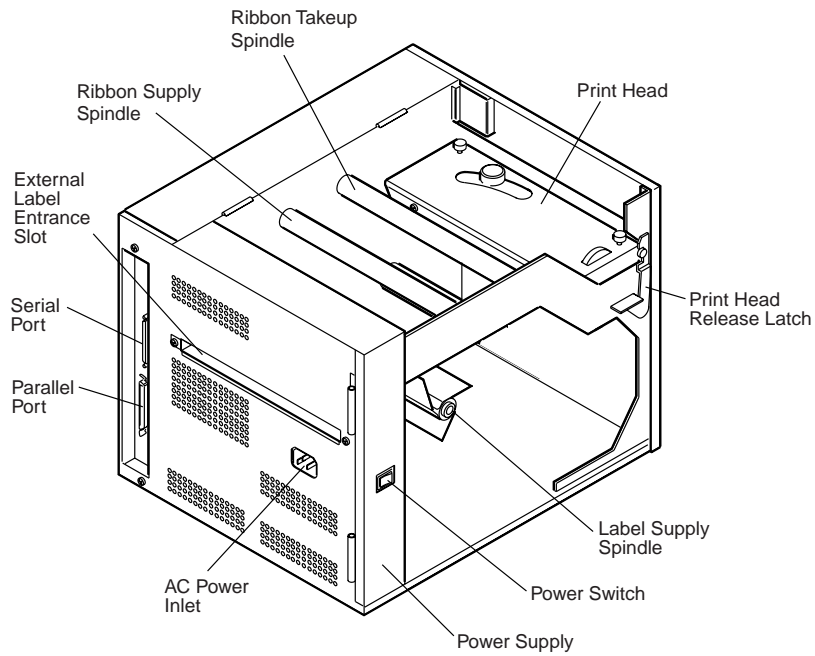

Figure 1-4 Model 88 Features (Rear and Left Side View)

HARDWARE DESCRIPTION

Printer operations are coordinated by control panel settings and the main board components under DC voltage from the power supply. The following subsections describe how printing is carried out.

- power supply
- control panel
- main board
- ribbon and paper feed mechanisms
- print mechanism (printer engine)

Power Supply

Alternating current (AC) is fed directly into the power supply and converted into the various DC voltages that drive and control printer operation (+5 V, +12 V, -12 V, +18 V, +24 V). The power supply contains one replaceable fuse.

Control Panel

The control panel contains the LCD display, power and alert indicators, and buttons that allow you to control and monitor printer operation. The 2-line display provides printer status and error messages and the printer settings menu tree. The power indicator shows whether the printer is turned on or off, while the alert indicator shows whether the printer has a fault or error condition that may affect operation. The control panel buttons allow you to view or change the printer settings (user parameters) via the menu tree.

For more information, see Section 3, “Unit Operation.”

Main Board

The main board (located behind the right side panel) controls communications between the computer and printer engine and coordinates the printer’s logic and mechanical functions. The printing process begins when the computer sends data to the main board through either the serial or parallel interface. The main board receives and interprets the data (HP LaserJet emulation and HP PCL language), develops the data in RAM, transmits the data to the print head for thermal transference, and coordinates the paper and ribbon feeding mechanisms.

The main board is functionally divided into two areas: the main or control area for image (video) processing and the sub area for engine control and print processing.

Figure 1-5 and Figure 1-6 show the locations of the connectors on each main board revision.

1-6 General Information

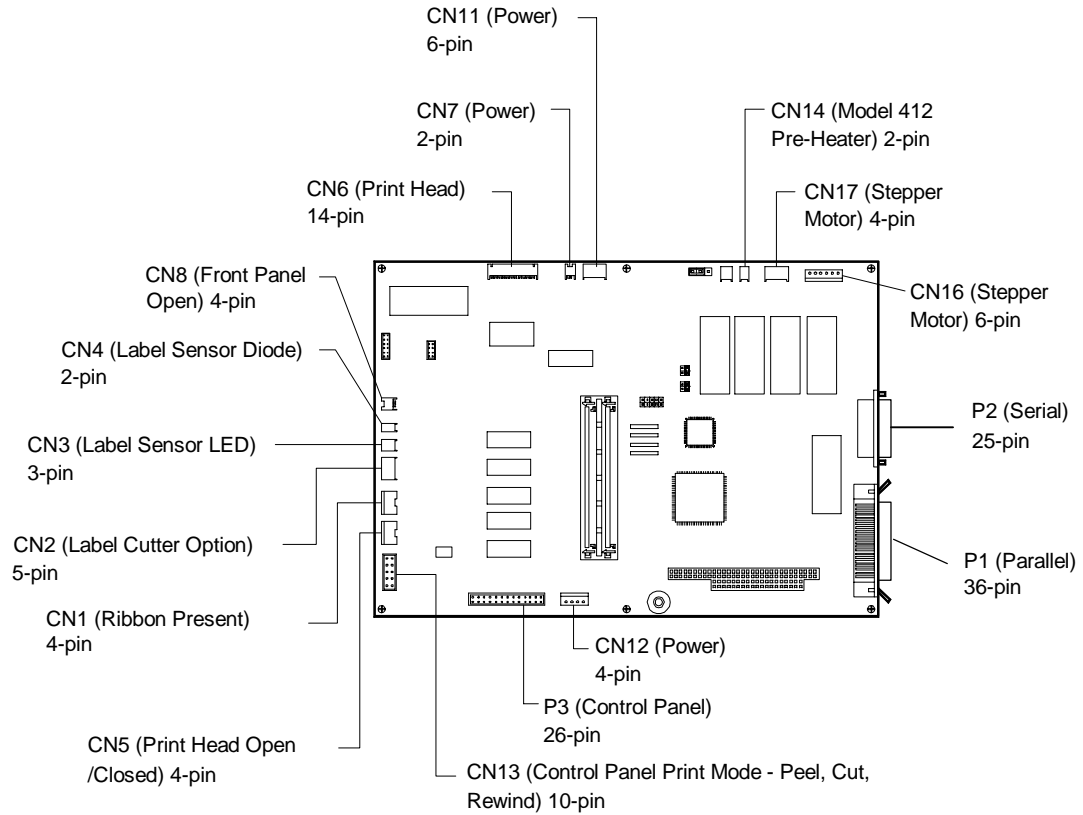

Figure 1-5 Main Board Revision 12, 13, or 14 Connector Locations

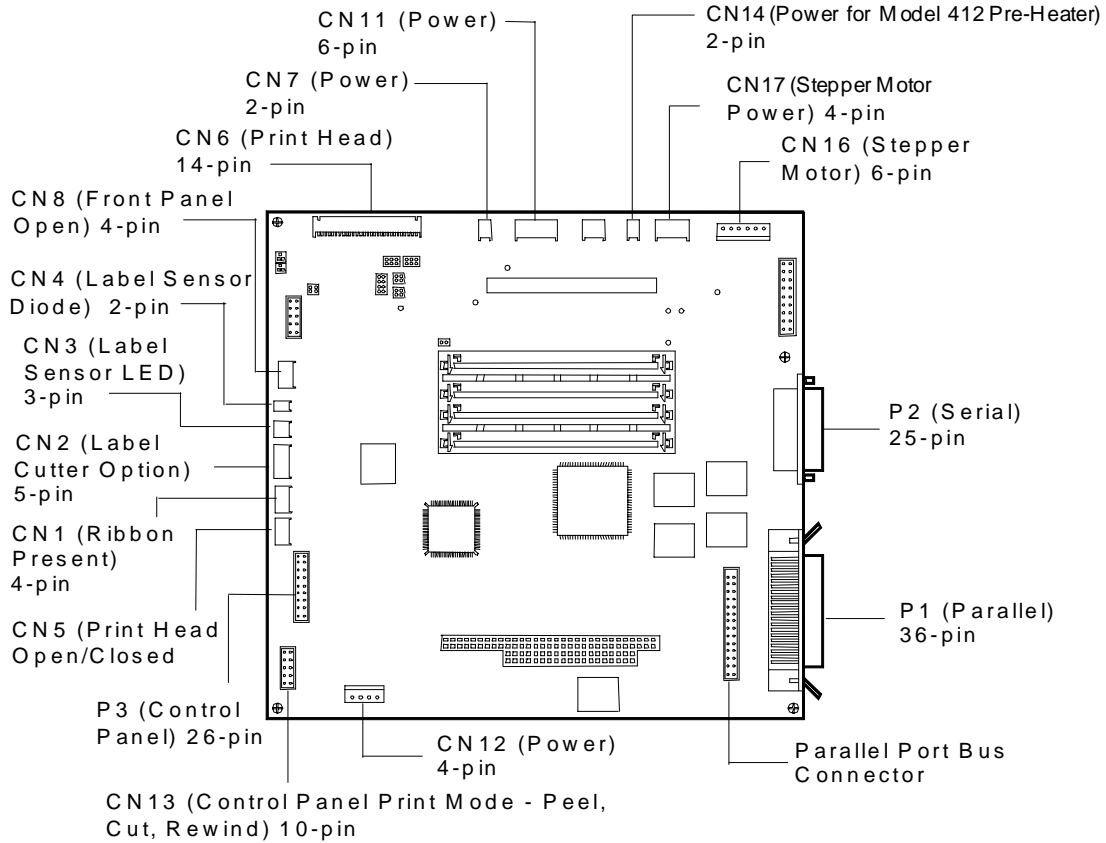

Figure 1-6 Main Board Revision 15 and 16 Connector Locations

Ribbon and Label Feed Mechanisms

This section describes the thermal transfer printing process carried out by the ribbon and label feed mechanisms.

NOTE: Direct thermal printing, where no ribbon is required and heat sensitive labels or tag stock are printed on directly, is not described in this section.

During the thermal transfer process, the ribbon and label feed mechanisms move the ribbon and labels between the platen and thermal print head. This confined space causes the ribbon to press against the label. Ink from the ribbon is applied to the label each time it crosses the print head by the heating of individual print head elements (resistors). The combination of heat from the resistors and pressure between the ribbon and label lays down the printed image.

The ribbon is fed by the stepper motor and is controlled by the main board and LED sensor settings (ribbon end sensor).

During the printing process, the label feed mechanism moves the label from the supply roller to the thermal print head and platen. Labels are fed by the stepper motor and by friction with the ribbon. Label feeding is coordinated by the main board, sensor settings (label sensor), and the control panel (see Section 3 for control panel settings that affect label feeding).

Figure 1-7 shows a simplified view of how thermal transference works. A cut-away diagram of the ribbon and label feed mechanism subassemblies for the Model 48 and 412 printers is provided in Figure 1-8.

NOTE: The ribbon and label feed subassemblies in the Model 88 printer differ in appearance from the Model 48 and 412, but the theory of operation is essentially identical as described below.

When the label and ribbon are fed between the platen and thermal print head, the label sensor detects the location of the 0.08-inch (2 mm) minimum gap between the labels on the paper roll and thus determines the position of the first print line on the label. A print command is then sent to the thermal print head by the engine control processor on the main board (see “Print Mechanism”).

Simultaneously, heat builds up in the thermal head heater, which contains a bank of resistors that selectively heat up, forming a printable image. The heat transfers ink on the ribbon to areas on the label surface that correspond to the heated resistors. This process fuses the image to the label.

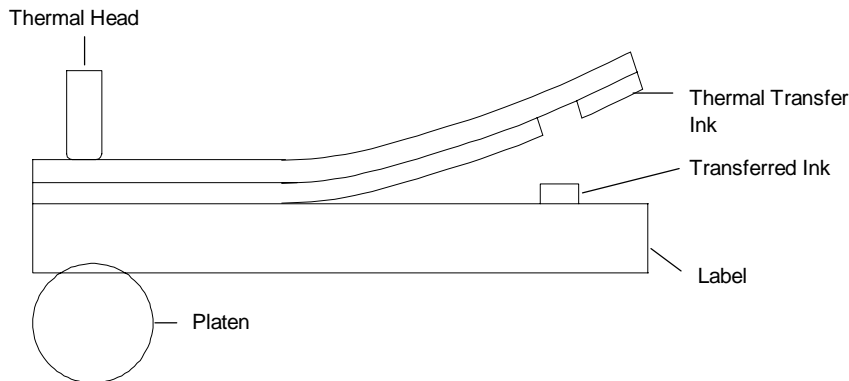

Figure 1-7 Thermal Transference

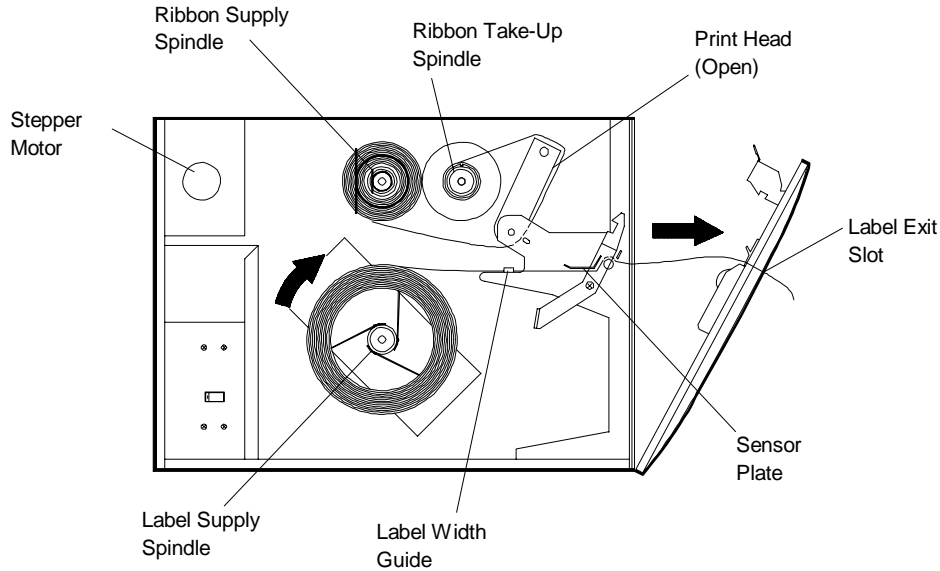

Figure 1-8 Ribbon and Label Feed Mechanisms (Model 48 and 412)

Print Mechanism

Printer engine functions are controlled by the engine control processor on the main board sub-area. The engine control processor sends control signals in response to commands and data received from the computer via the PC/AT core. The control and data signals heat the thermal print head elements (resistors) as previously described in “Ribbon and Paper Feed Mechanisms.” Control and data signals from the engine control processor also drive the stepper motor for feeding the ribbon and labels through the printer. When the label or ribbon sensors detect that the printer has run out of labels or ribbon (or when label jams occur), the information is relayed from the engine control processor, and the appropriate message appears on the control panel LCD (see Section 3 for display messages).

Depending on print speed, a specified “high” or “low” voltage is sent from the power supply to the heater inside the thermal print head. During normal speed printing (2.4 ips to 12 ips) typically used with wax ribbons, the power supply provides a “high” voltage of approximately 24V. This voltage can be changed using the control panel menu buttons (see “Print Head Voltage Adjustment” in Section 5).

During low speed printing (0.6 ips to 1.6 ips) typically used with resin ribbons, a “low” voltage of approximately 12V is used. This voltage can also be changed using the control panel menu buttons (see “Print Head Voltage Adjustment” in Section 5).

Print speed is controlled by sending the appropriate strobe (STB) pulse (STB1 or STB2 applied pulse) according to the temperature information sent from the print head thermistor. For high speed printing (10 ips to 12 ips), the print head is pre-heated to an optimum head temperature of 50° C per resistor. If the head temperature exceeds 70° C, printing stops and a head temperature message is reported on the control panel (see Section 2 for display messages).

NOTE: During printing, the actual temperature of a resistor can exceed 200° C for a few milliseconds.

MEMORY EXPANSION

Depending on the main board revision installed in the printer, memory expansion can be done in the IntelliBar Model 48 and 412 through the purchase of industry-standard, user-installable, SIMM memory modules made for Apple or PC products. SIMM modules are available from retail or mail order computer hardware suppliers. These modules install in pairs in two expansion slots on the main board and increase the printer's standard memory capacity from the standard 2 MB to a maximum of 10 MB.

NOTE: The Model 88 contains a total of 10 MB of standard printer memory which is not expandable.

See Table 4-1 and Table 4-2 in Section 4 for memory installation guidelines and procedures.

OPTIONS

IntelliTech International, Inc. options for the IntelliBar printer are divided into two categories: user-installable and factory-installable. Each category is described below. Section 4 provides additional information on *IntelliTech* International, Inc. printer options (including installation procedures and dealer order numbers).

User-Installable Options

User installable options for the IntelliBar Models 48 and 412 include the following.

- Label Cutter (Model 2401) — Lets you quickly print and process labels for immediate application. This user-installable option fits in the front panel in place of the standard peel-off assembly. You must also remove the tear bar from above the platen roller (see Section 3 for label cutter installation procedures).
-

The cutter is designed for users who require on-demand label printing (usually one label at a time) and the convenience of a label precut and ready to apply. The printer can be programmed to print a number of labels (up to 32,767) and then perform the cut function.

The cutter is designed to cut only paper or synthetic label backing (liner) and can also cut continuous media that contains no rubber based adhesives.

NOTE: The maximum thickness of labels used with the cutter option is 0.005 in. (0.127 mm).

- External Rewinder (Model 2402) — Mounts in front of the printer and rewinds labels. Allows you to output labels that can be conveniently spooled for storage or shipment to another location.

Factory-Installable Options

Factory-installable options for the IntelliBar Models 48 and 412 include the following.

- Internal Rewinder (Model 2405) — This option mounts inside the IntelliBar and can be used to spool printed media (labels and backing paper) for convenient storage or transportation of labels in volume quantity. You can also use the rewinder option to spool only the backing paper in peel-off print mode.
- Reflective Label Sensor (Model 2404) — This field- or dealer-installable option replaces the printer's standard, transmissive (see-through) label sensor. This option reflects light off the black stripe when tag or ticket stock is fed through the printer and thereby detects the label's home position (used for determining the first print line on the label). This option can also be used on butt-cut or specialty die-cut labels.

SPECIFICATIONS

Table 1-2 lists printer specifications for the IntelliBar Standard series. Specifications for the IntelliBar AS Series, ax Series, and LPR Series are the same except as differentiated in Table 1-1 for the printer command language, emulation, and connectivity.

NOTE: For updates on IntelliBar printer specifications and other information about *IntelliTech* International, Inc. products, visit our Web site at <http://www.intellibar.com>.

Table 1-2 IntelliBar Standard Series Specifications

Feature	Model 48, 48E	Model 412, 412E	Model 88, 88E
Print method	Thermal transfer or direct thermal		
Resolution	300 x 300 dots per inch (11.81 dots per mm)		
Print widths	4.37" (111 mm) maximum		8.65 in. (220 mm) maximum
Print length (standard)*	14 in. (356 mm)	28 in. (711.2 mm)	14 in. (356 mm)
Print length (maximum)*	99 in. (2,515 mm)	99 in. (2,515 mm)	99 in. (2,515 mm)
Print speed	.6 in. up to 8 in. per second	.6 in. up to 12 in. per second	.6 in. up to 8 in. per second
Memory	2 MB standard, 10 MB maximum	2 MB standard, 10 MB maximum	10 MB standard (not expandable)
Dimensions	12.4 in. H x 9.4 in. W x 16 in. D (315 H mm x 239 mm W x 406 mm D)		13.2 in. H x 14.4 in. W x 17 in. D (335 mm H x 366 mm W x 432 mm D)
Control Panel	LCD, 16 character, 2 line status and error display		
Interface	IEEE 1284 (parallel) and RS-232C/RS-422C (serial) Baud rate: 1200 - 38,400 bps		
Emulation	Hewlett Packard LaserJet III (HP PCL 5, HP GL/2)		
Fonts	14 bit map fonts, 8 AGFA IntelliFont scalable typefaces (CG Times, Univers Bold)		
Bar codes	UPC-A, UPC-E, EAN/JAN-13, EAN/JAN-8, UPC/EAN extension (2 of 5 digit supplemental), 3 of 9 (Code 39), Extended 3 of 9, Interleaved 2 of 5, Code 128, Codebar, Zip +4, Postnet, MSI Plessey, Code 93, Extended 93, UCC-128, HIBC, PDF417		
Electrical	115 VAC \pm 10%, 50/60 Hz. 230 VAC \pm 10% 50/60 Hz IEEE 1284 compliant cable required		

* See Section 2 for print media specifications.

Table 1-2 IntelliBar Standard Series Specifications

Feature	Model 48, 48E	Model 412, 412E	Model 88, 88E
Operating environment	41° F – 104° F (5° C – 40 C); below 85% non-condensing humidity		
Agency certifications	UL-1950, C-UL, FCC Class A (115 VAC); TUV EN69050, CE mark (230 VAC)		
User-installable options	Label Backing Cutter: Model No. 2401** External Label Rewinder: Model No. 2402		Label Cutter: 240X
Factory-installed options	Reflective Sensor (Model 2404) Internal Rewinder (Model 2405)		Reflective Sensor 240X Internal Rewinder 240X
Warranty (U.S)	One-year limited warranty; printhead warranted for 90 days or 500,000 linear inches, whichever comes first		
Media	Die cut and continuous paper stocks, synthetic stocks, tag stock, ticket stock		
Label finishing	Standard: Continuous, tear off and on-demand peel off (self strip). Cut off: optional		
Label specifications	Label print width: .75 in. min. to 4.37 in. max. (19 mm to 111 mm)		4.37 in. minimum to 8.65 in. maximum (111 mm to 222 mm)
	Label print length: .5 in. minimum. to 99 in. maximum*** (13 mm to 2,515 mm)		
	Minimum. label gap: .125 in. (3.2 mm)		
	Maximum label thickness: .01 in. (.245 mm)		
	Maximum roll diameter: 8 in. (203 mm); 7 in.(178 mm) with Internal Rewinder installed		8 in. (203 mm)
	Inner core diameter: 3 in. (76.2 mm)		
	Label web width: .75 in. min. to 4.56 in. max. (19 mm to 116 mm)		4.56 in. min. to 9.5 in. max. (116 mm to 241 mm)
Ribbon types	Express Wax for high-speed printing up to 12 inches per second Dura Wax for economical printing Rugged Resin for durability and smudge resistance Dura Resin Plus for chemical, heat and scratch resistance Dura Wax/Resin for monochromatic color printing		
Ribbon length	Wax Ribbons: 1,475 feet (450 meters); Resin Ribbons: 984 feet (300 meters)		
Ribbon widths	1.06 in., 2.12 in., 3.27 in., 4.37 in. (27 mm, 54 mm, 83 mm, 111 mm)		4.37 in., 7 in., 8.65 in. (111 mm, 178 mm, 222 mm)

** Not intended for use with rubber-based adhesives.

*** With additional optional memory installed and page protect turned off.

INTERFACE

This section describes IntelliBar interfaces for communicating with the host computer or network computer. The printer is equipped with two interface communication ports:

- 36-pin IEEE 1284 parallel (connector P1)
- 25-pin RS-232C serial/RS-422 serial (connector P2)

To select the interface, use the control panel menu tree as described in Section 3.

Parallel Interface

This section describes the IntelliBar parallel port interface.

The IEEE 1284 parallel input allows no parameters. It always accepts 8-bit data with no parity. For communication functions, it reserves the same set of characters reserved by the serial port, with the exception of X-ON and X-OFF characters.

Note that the IEEE 1284 parallel interface is essentially an input-only channel. The parallel port communicates in one direction, which is from the host computer to the printer.

IEEE 1284 Cable Requirements

The cable connected to the parallel interface port must be fully shielded and fitted with the proper connector shell. Keep parallel cables as short as possible (8 ft. maximum) and do not route or connect them near electrical conduits or high-voltage power lines.

To ensure the cable meets IEEE 1284 specifications, a cable labeled *IEEE-1284 compliant* is required and is a simple way to guarantee good cable design. A cable with this label contains the IEEE 1284-standard of 36 twisted-pair wires and is properly shielded.

Serial Interface

This section describes the IntelliBar serial interface. IntelliBar serial communications meets the following specifications:

- asynchronous
- 8 data bits per character
- no parity
- one start bit
- one stop bit

Three parameters are used to control serial communication: channel, baud rate, and options.

The baud rate is given as an integer (such as 1200 or 9600), and the maximum supported baud rate is 38,400 bits per second (bps). Standard baud rates supported by the IntelliBar are as follows.

- 300
- 600
- 1200
- 2400
- 4800
- 9600
- 19,200
- 38,400

Data Transmission

The printer uses Robust X-ON/X-OFF protocol to control transmitted and received character flow.

At power-on, the serial controller carries out communication as soon as the hardware and software are initialized. Hence, the first character sent in X-ON/X-OFF mode will be X-ON (rather than X-OFF).

Available in Menu Mode using the control panel menu buttons, Robust X-ON/X-OFF flow control determines if additional X-ONs should be transmitted.

If Robust X-ON/X-ON is set to ON (the default), additional X-ONs will be transmitted at one second intervals until data is received. If it is set to OFF using the control panel (see Section 3), no additional X-ONs are sent.

NOTE: The information in this section is subject to change without notice. This information is provided "as is" without either express or implied warranty. *IntelliTech* International, Inc. disclaims any and all warranties with regard to this information. *IntelliTech* shall not be liable in any event for any special, indirect or consequential damages or any damages whatsoever resulting from loss of data, profits or use, for any reason or in any action, arising out of or in connection with the use or performance of this information.
